

# DESIGN NOTES

## Step-Up/Step-Down DC/DC Conversion Without Inductors

Design Note 189

Sam Nork

### Introduction

Many applications require a regulated supply from an input source that may be greater than or less than the desired output voltage. Such applications place unique constraints on the DC/DC converter and, as a general rule, add complexity and cost to the power supply. A typical example is generating 5V from a 4-cell NiCd battery. When the batteries are fully charged, the input voltage is around 6V. When the batteries are near end of life, the input voltage may be as low as 3.6V. Maintaining a regulated 5V output for the life of the batteries typically requires an inductor-based DC/DC converter (for example, a SEPIC converter) or a complex, hybrid step-up/step-down solution. The LTC<sup>®</sup>1514/LTC1515 family of switched capacitor DC/DC converters handles this task using only three external capacitors (Figure 1).

A unique architecture allows the parts to accommodate a wide input voltage range (2.0V to 10V) and adjust the operating mode as needed to maintain regulation. As a result, the parts can be used with a wide variety of battery configurations and/or adapter voltages (Figure 2). Low power consumption ( $I_Q = 60\mu\text{A}$  typical) and low external parts count make the LTC1514 and LTC1515 well suited for space-conscious, low power applications, such as cellular phones, PDAs and portable instruments. The parts come in adjustable and fixed output voltages and include additional

features such as power-on reset capability (LTC1515 family) and an uncommitted comparator that is kept alive during shutdown (LTC1514 family).

### Regulator Operation

The parts use a common internal switch network to implement both step-up and step-down DC/DC conversion. The action of the switch network is controlled by internal circuitry that senses the voltage differential between  $V_{IN}$  and  $V_{OUT}$ . When the input voltage is lower than the output voltage, the switch network operates as a step-up voltage doubler with a free-running frequency set by the internal oscillator (650kHz typ). When the input voltage is greater than the output, the switch network operates as a step-down gated switch. Regulation is achieved by comparing the divided output voltage to the internal reference voltage. When the divided output drops below the reference voltage, the switch network is enabled to boost the output back into regulation. The net result is a stable, tightly regulated output supply that can tolerate widely varying input voltages and load transients (Figures 3 and 4).

 LTC and LT are registered trademarks of Linear Technology Corporation.

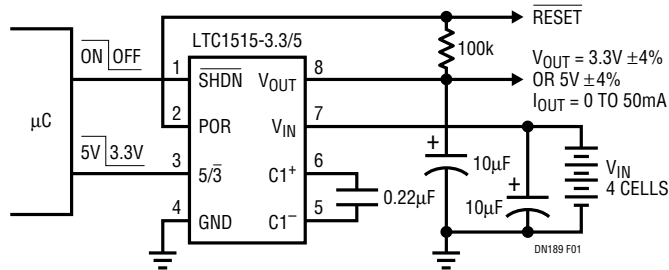

**Figure 1. Programmable 5V/3V Power Supply with Power-On Reset**

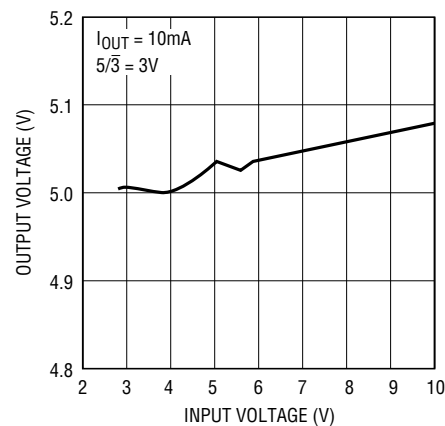

**Figure 2. LTC1515-X 5V Output Voltage vs Input Voltage**

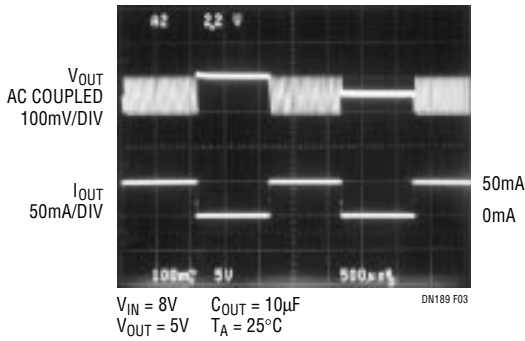

**Figure 3. LTC1515-X Step-Down Mode 5V Load Transient Response**

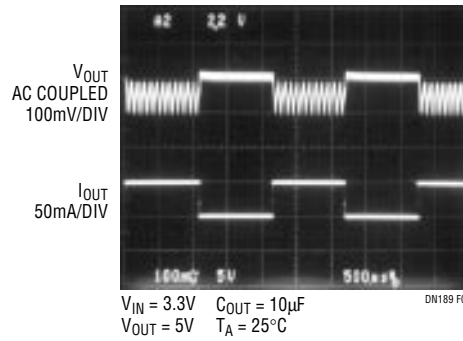

**Figure 4. LTC1515-X Step-Up Mode 5V Load Transient Response**

### Dual Output Supply from a 2.7V to 10V Input

The circuit shown in Figure 5 uses the low-battery comparator to produce an auxiliary 3.3V regulated output from the  $V_{OUT}$  of the LTC1514-5. A feedback voltage divider formed by R2 and R3 connected to the comparator input (LBI) establishes the output voltage. The output of the comparator (LBO) enables the current source formed by Q1, Q2, R1 and R4. When the LBO pin is low, Q1 is turned on, allowing current to charge output capacitor C4. Local feedback formed by R4, Q1 and Q2 creates a constant current source from the 5V output to C4. Peak charging current is set by R4 and the  $V_{BE}$  of Q2, which also provides current limiting in the case of an output short to ground. With the values shown in Figure 5, the auxiliary regulator can deliver up to 50mA before reaching its current limit. However, the combined output current from the 5V and

3.3V supplies may not exceed 50mA. Since the regulator implements a hysteretic feedback loop in place of the traditional linear feedback loop, no compensation is needed for loop stability. Furthermore, the high gain of the comparator provides excellent load regulation and transient response.

### Conclusion

With low operating current, minimal external parts count and robust protection features, the LTC1514 and LTC1515 offer a simple and cost-effective solution to low power step-up/step-down DC/DC conversion. The shutdown, POR and low-battery-detect features provide additional functionality. The ease of use and versatility of these parts make them ideal for low power DC/DC conversion applications.

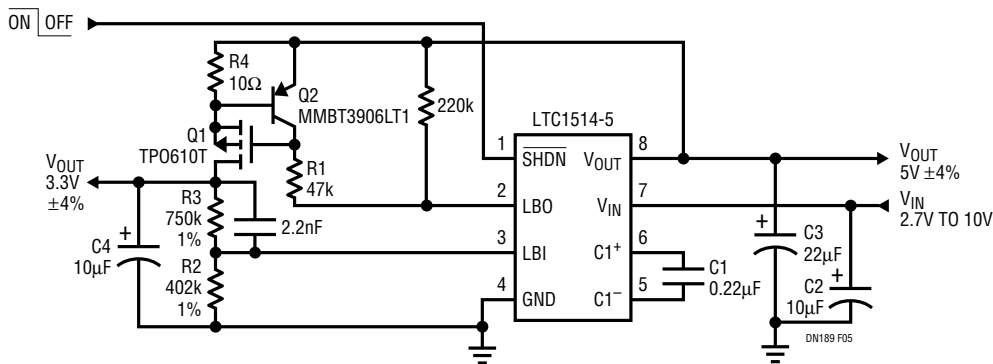

**Figure 5. Low Power Dual Output Supply (Maximum Combined  $I_{OUT} = 50mA$ )**

For literature on our DC/DC Converters, call **1-800-4-LINEAR**. For applications help, call (408) 432-1900, Ext. 2593